

SKSUD2402P

Convertible undertop refrigerator



FRONT VIEW

SIDE VIEW

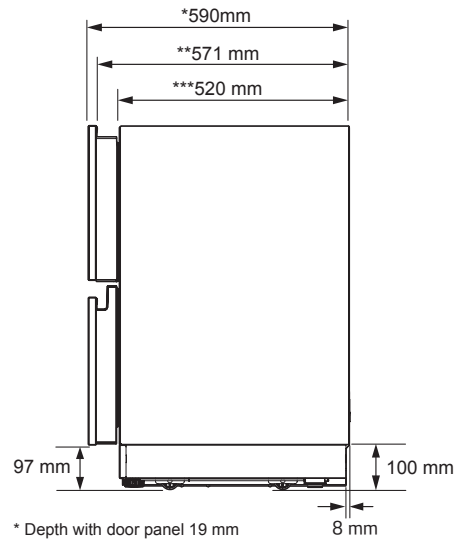
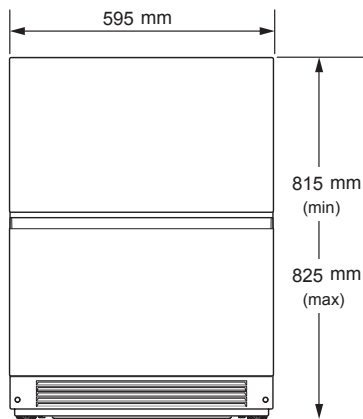

* Depth with door panel 19 mm
** Depth without door panel
*** Depth of the unit

VIEW FROM ABOVE

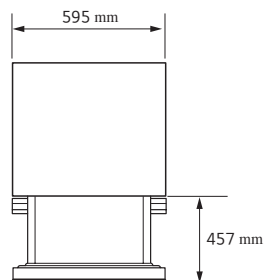

SKSUD2402P*

Style	EAN: 8806091740946
Door Style	Panel Ready
Interior finish	Stainless Steel
Energy Label	
Energy Efficiency Class	F
Bottle Capacity (750 ml)	96 l
Maximum Sound Level	< 37 dbA Max
General Properties	
Net Total Capacity	96 l
Maximum Sound Level	< 34.6 dbA Max
ENERGY STAR® Qualified	●
No-Frost	●
Inverter Linear Compressor	●
Wi-Fi-Enabled for SmartThinQ® Control with iOS/Android App	●
Automatic Adaptive Defrost	●
Modes	Freezer (-21 C° to -15 C°), Meat and seafood (-1 C°), Bar (1 C°), Refrigerator (2 to 6 C°), Pantry (10 C°)
Speed Freeze	●
True-View® Lighting	●
Digital Controls w/ White LED Display	●
Operating Temperatures	-24°C to 10°C
Installation	
Reversible Door	●
Four Point Front Adjustable with 8 Wheels	●
Attachment Method to Cabinetry	Top with No Visible Screws
Front Serviceable	●
Anti-tip Bracket Included	●
Technical Specifications	
Overall Width	595 mm
Overall Height	min 815 mm ~ max 825 mm
Overall Depth	571 mm
Net Weight	138 kg
Shipping Weight	158 kg
Accessories	
24" Undertop refrigerator - Stainless steel door kit	SKSUK240DS

* Product available as of October 2022